

Technical Information Sheet

Product Code: 8E1400X



8" End Port Pressure Vessel

END PORT

1400 psi (96.6 bar)

ASME X

Working Pressure: **1400 psi**
 Assembly Drawing: **1MNC 3040**

Working Temperature: **-7 to 45°C**
 Design Code: **ASME X**

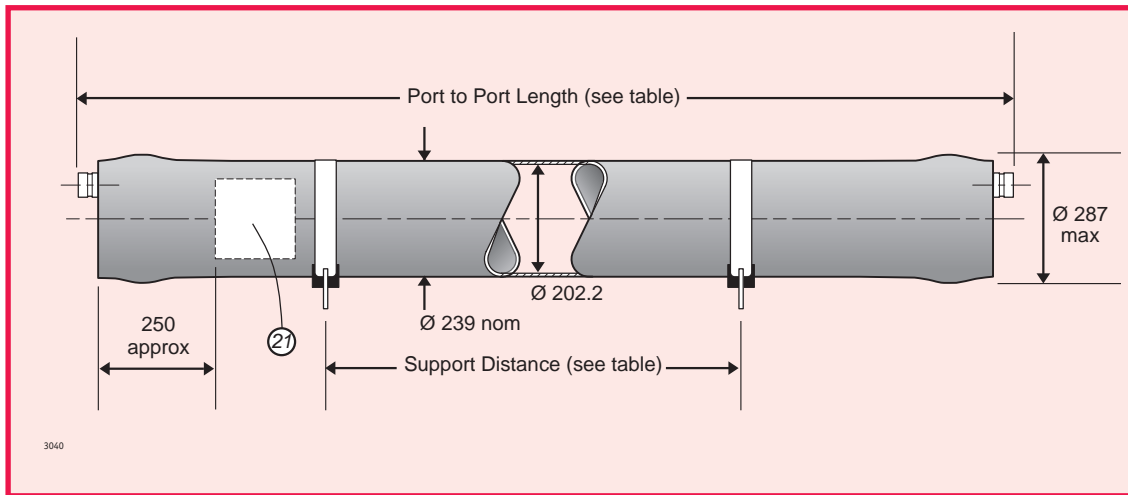

Body of vessel is manufactured completely from glass reinforced epoxy resins.

Please advise membrane type and length when requesting further details.

Pressure vessels can be produced to cover all leading manufacturers membranes regardless of length.

Please adhere to recommended support positions, if in doubt contact Phoenix Vessels.

Feed and concentrate connections: 1.5" Victualic

Product connections: 1.0" NPT Parallel (Male)

No of 40" Elements	Port to Port Length +/-7mm	Max support position	Min support position	Max Dry Weight
1	1702	875	500	67 kg
1.5	2210	1400	500	81 kg
2	2718	1890	500	95 kg
3	3734	2910	960	121 kg
4	4750	3190	1970	148 kg
4.5	5258	3375	2480	162 kg
5	5766	3560	2990	176 kg
6	6782	4020	4020	201 kg
7	7798	6170 c	5090 c	229 kg
7.5	8306	6220 c	5330 c	243 kg

All dimensions in mm
 All dimensions and weights are nominal unless stated otherwise.

c = Central support required

Phoenix Vessels

8" End Port Pressure Vessel

END PORT

1400 psi (96.6 bar)

ASME X

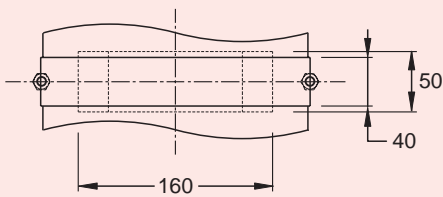
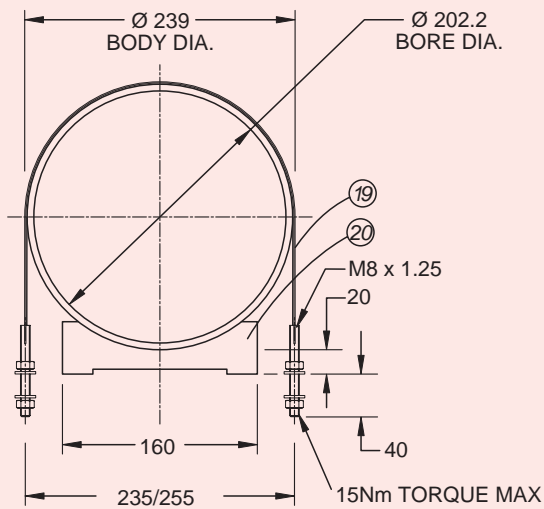
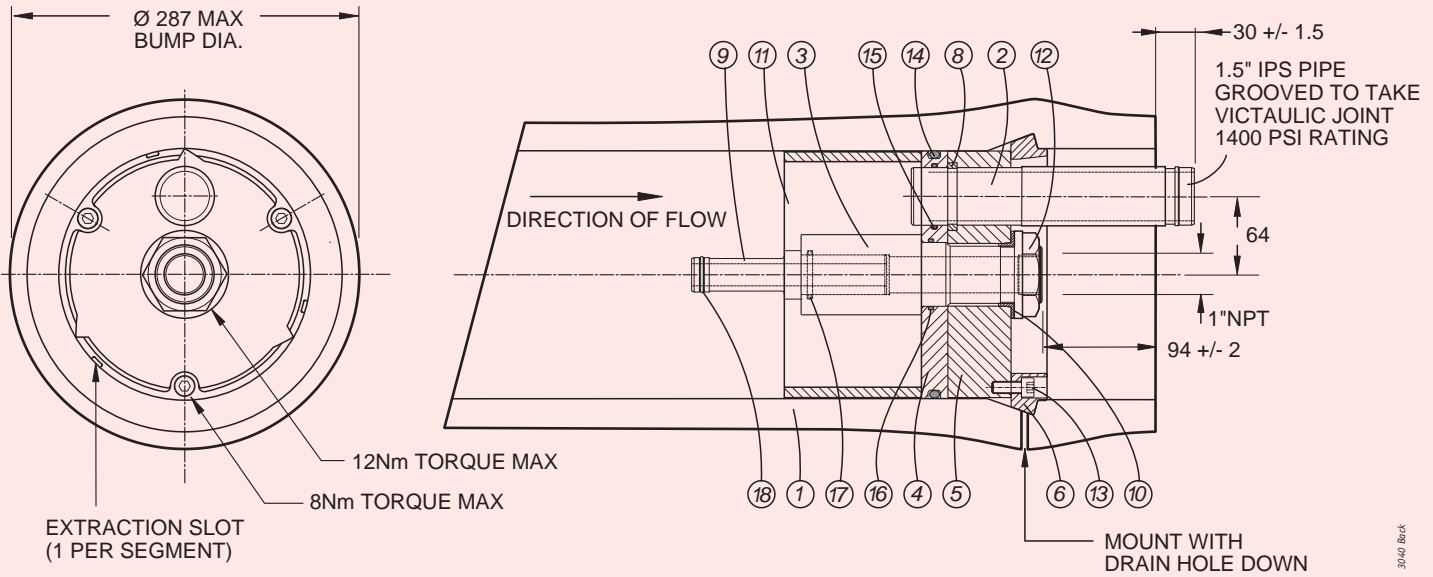

Tighten all bolts/nuts to 50% of the maximum torque figure.
DO NOT EXCEED THE MAXIMUM TORQUE.

For lubricants and general assembly refer to the User Guide.

Item	Description	Material	Part No	No. off
1	Vessel Body	Glass Fibre Epoxy Resin	PVL 80-14-3120	1
2	Feed/Concentrate Port	Duplex UNS S32750/60	PVL 80-12-1650	2
3	Product Tube	Thermoplastic	PVL 80-12-1953	2
4	End Plate	Thermoplastic	PVL 80-12-1397	2
5	Backing Plate	Anodised Aluminium 6061-T6	PVL 80-12-1818	2
6	Retaining Ring	Stainless Steel 316	PVL 80-10-1470	2
7				
8	Retaining Ring (Port)	Stainless Steel 316	PVL 80-10-1176	2
9	Adaptor	Thermoplastic	To suit membrane	2
10	Anti-rotation Collet	Thermoplastic	PVL 80-12-1894	2
11	Thrust Ring	Thermoplastic	To suit membrane	1
12	1.5" BSP Backnut	Thermoplastic	PVL 80-12-1979	2
13	Cap Head Screw	Stainless Steel A4	PVL 80-10-1520	6
14	'O' Seal Endplate	EPDM	Size BS882	2
15	'O' Seal Feed Port	EPDM	Size BS225	2
16	'O' Seal Prod/Endplate	EPDM	Size BS832	2
17	'O' Seal Prod/Adaptor	EPDM	Size BS219	2
18	'O' Seal Adaptor	EPDM	To suit membrane	2
19	Strap	Stainless Steel/Neoprene	PVL 80-12-1836	2/3
20	Saddle	Urethane	PVL 80-10-1075	2/3
21	Nameplate	Aluminium or Vinyl		1

The company reserves the right to alter specifications without prior notice.



Phoenix Vessels Ltd

Unit 2, The Old Bakery, Lower Tuffley Lane, Gloucester GL2 5DP
 Telephone: (01452) 311673 Fax: (01452) 310295
 e-mail: info@phoenixvessels.co.uk
 Internet: www.phoenixvessels.co.uk

