

Technical Information Sheet

Product Code: 8S450N



8" Side Port Pressure Vessel

SIDE PORT

450 psi (31.0 bar)

Working Pressure: **450 psi**
 Assembly Drawing: **1MNC 3312**

Working Temperature: **-7 to 45°C**
 Does not conform to ASME X

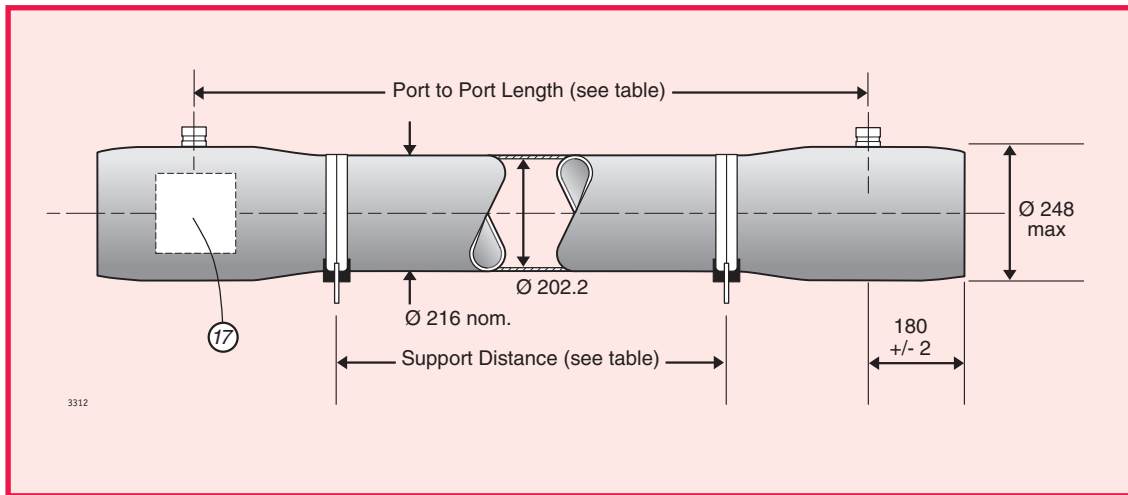

Body of vessel is manufactured completely from glass reinforced epoxy resins.

Please advise membrane type and length when requesting further details.

Pressure vessels can be produced to cover all leading manufacturers membranes regardless of length.

Please adhere to recommended support positions, if in doubt contact Phoenix Vessels.

Feed and concentrate connections: 1.5" or 2.0" Victualic (For options see reverse)

Product connections: 1.0" BSP Parallel (Female)

No of 40" Elements	Port to Port Length +/-1mm	Max support position	Min support position	Max Dry Weight
1	1143	740	500	49 kg
1.5	1651	1250	500	54 kg
2	2159	1750	500	59 kg
3	3175	2775	960	70 kg
4	4191	3190	1970	81 kg
4.5	4699	3375	2480	87 kg
5	5207	3560	2990	92 kg
6	6223	4020	4020	104 kg
7	7239	6170 c	5090 c	115 kg
7.5	7747	6220 c	5330 c	121 kg

All dimensions in mm
 All dimensions and weights are nominal unless stated otherwise.

c = Central support required

Phoenix Vessels

8" Side Port Pressure Vessel

SIDE PORT

450 psi (31.0 bar)

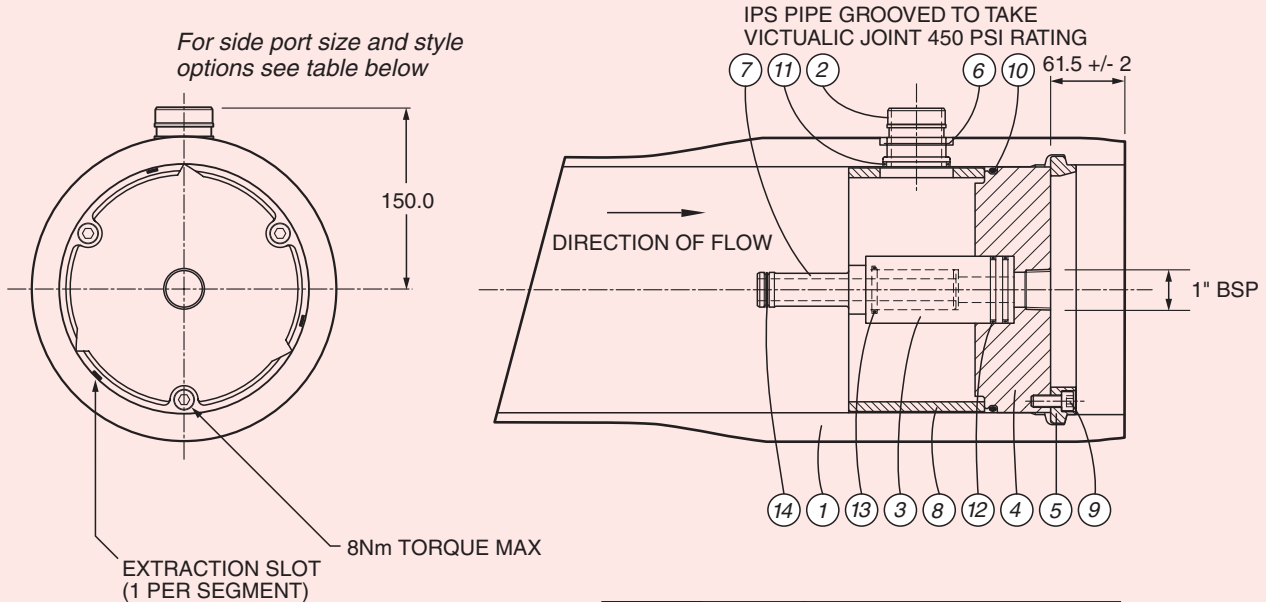

SIDE PORT OPTIONS	SIZE	STYLE
	1.5"	1) 2 Same side - 0°,0°
	2.0"	2) 2 Opposing - 0°,180°
		3) 4 port - 0°,180°

Item	Description	Material	Part No	No. off
1	Vessel Body	Glass Fibre Epoxy Resin	PVL 3148	1
2	Feed/Concentrate Port	Stainless Steel 316L 1.5" Port Stainless Steel 316L 2.0" Port	PVL 1863 PVL 1990	2/4 2/4
3	Hub	Thermoplastic	PVL 80-02-1550	2
4	End Cap	Thermoplastic	PVL 1947	2
5	Retaining Ring	Stainless Steel 316	PVL 1886	2
6	Spiroloc Circlip	Stainless Steel 302 1.5" Port Stainless Steel 302 2.0" Port	PVL 1950 PVL 2029	2/4 2/4
7	Adaptor	Thermoplastic	To suit membrane	2
8	Thrust Ring	Thermoplastic	PVL 3069	1
9	Cap Head Screw	Aluminium	CMP 1520	6
10	'O' Seal Endplate	EPDM	Size BS882	2
11	'O' Seal Feed Port	EPDM 1.5" Port EPDM 2.0" Port	Size BS225 Size BS229	2/4 2/4
12	'O' Seal Prod/Endplate	EPDM	Size BS220	2
13	'O' Seal Prod/Adaptor	EPDM	Size BS219	2
14	'O' Seal Adaptor	EPDM	To suit membrane	2
15	Strap	Stainless Steel/Neoprene	PVL 1836	2/3
16	Saddle	Urethane	PVL 1075	2/3
17	Nameplate	Aluminium or Vinyl		1

Tighten all bolts/nuts to 50% of the maximum torque figure.
DO NOT EXCEED THE MAXIMUM TORQUE.

For lubricants and general assembly refer to the User Guide.

The company reserves the right to alter specifications without prior notice.



Phoenix Vessels Ltd

Unit 2, The Old Bakery, Lower Tuffley Lane, Gloucester GL2 5DP
Telephone: (01452) 311673 Fax: (01452) 310295
e-mail: info@phoenixvessels.co.uk
Internet: www.phoenixvessels.co.uk

