

# SOFTENING

## SOFT - CAB

### Watersoftening Optimisation

Compact-Softening Cabinets suitable for domestic and commercial use. Particularly useable for those cases where economic optimisation is considered with regard to place-, energy-, water required as well as salt consumption for water softening.

### Calcium Precipitation Cost Money

Calcium precipitations damage considerably the domestic and commercial installations, reduce the lifetime and efficiency of all connected facilities and equipment, such as dish washers and washing machines, boilers, coffee-makers etc. Early exchange and repairs cause unnecessary expenses. A thin layer of those deposits increases the power consumption overproportional.

Energy losses due to calcium deposits

Layer thickness ( mm )	0,4	0,8	1,6	3,2	4,8
Energy loss ( in % )	4	7	11	18	27

The growing limestone layer causes at electrical facilities overheatings and burn outs, friction losses which concerns the lifetime of the feed pump, fittings wear out earlier. Moreover lime spots on tiles, basins and baths appear and the soap- and detergent consumption arises. By assembly a water softening plant the problems disappear.

### Design

The **SOFT - CAB**'s main part is a strong and solid PE tank in which the resin tank the regeneration salt and all control devices are built in.. The resin is under strict quality control. The also built-in brine valve ensures the provision of the brine. The central control valve operates the process steps "service, back wash, regeneration, drains and fast rinse"..

Two types of casings are use: Type A for electromechanical controlled valves, Type B for electronic controlled valves.

### Central Control Valves

- 1) The world-wide used „ Fleck “ - Valves are operating and controlling the single regeneration steps by different controller types ( electromechanical or electronic controllers )
- 2) For an approved higher standard ( parts checked and allowed to Germans DVGW guidelines, DIN 19636 ) the Cabinet can be equipped with the Fleck valve 6665 HPE. It is an electronic central control valve made from

plastic with optical indications, salt lack warning and safety device against biological growth.

### Data

Type	<b>SOFT - CAB</b>	„S“	„L“	„XL“
Resin Volume ( ltr.)		13	18	25
Salt Storage ( kg )		115	110	105
Salt Cons./Reg. ( kg )		1,6	2,4	3,2
Flow maximum (m <sup>3</sup> /h)		1,5	2,0	2,6
Capacity (m <sup>3</sup> x °dH)		50	80	110
Oper. Pressure min./max.		1,4 / 8,5 bar		
Water temperature. max.		43 °C		
Electrical. Supply		230V/50 Hz		
Controller	optional	Volume/Time		

**SOFT - CAB**  
Type B



**SOFT - CAB** Type A  
( Head



# Domestic Softener *SOFT - CAB*

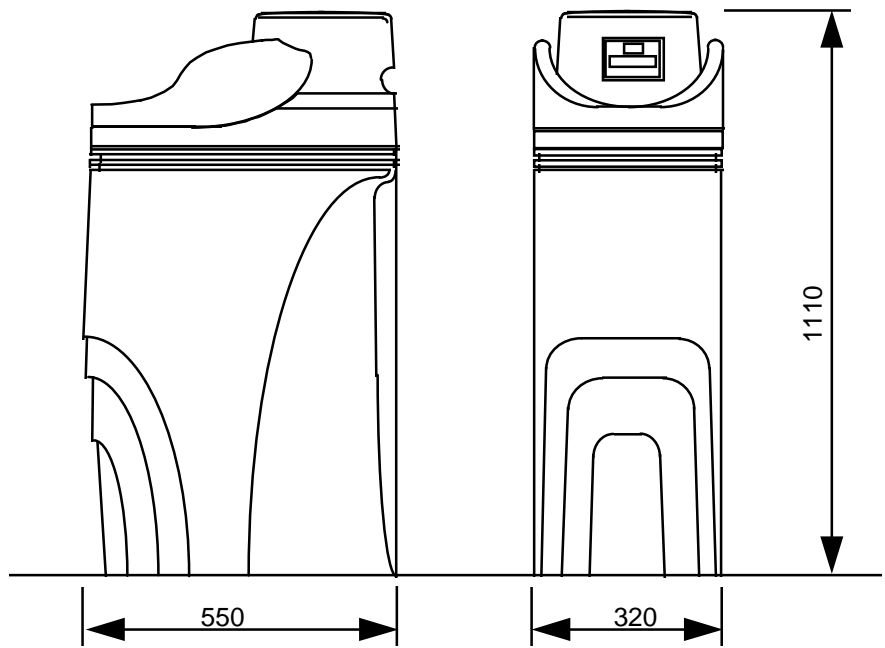

Typ *SOFT - CAB S*

Typ *SOFT - CAB L*

Typ *SOFT - CAB XL*

