

1:2

MODEL	VOLUME		DOME VOLUME		WEIGHT			
	liters	U.S. gal	cubic FT	liters	U.S. gal	cubic FT	Kg	LBS
18x65	275L	72.66	9.72	17.3	4.57	0.61	33.57	73.85

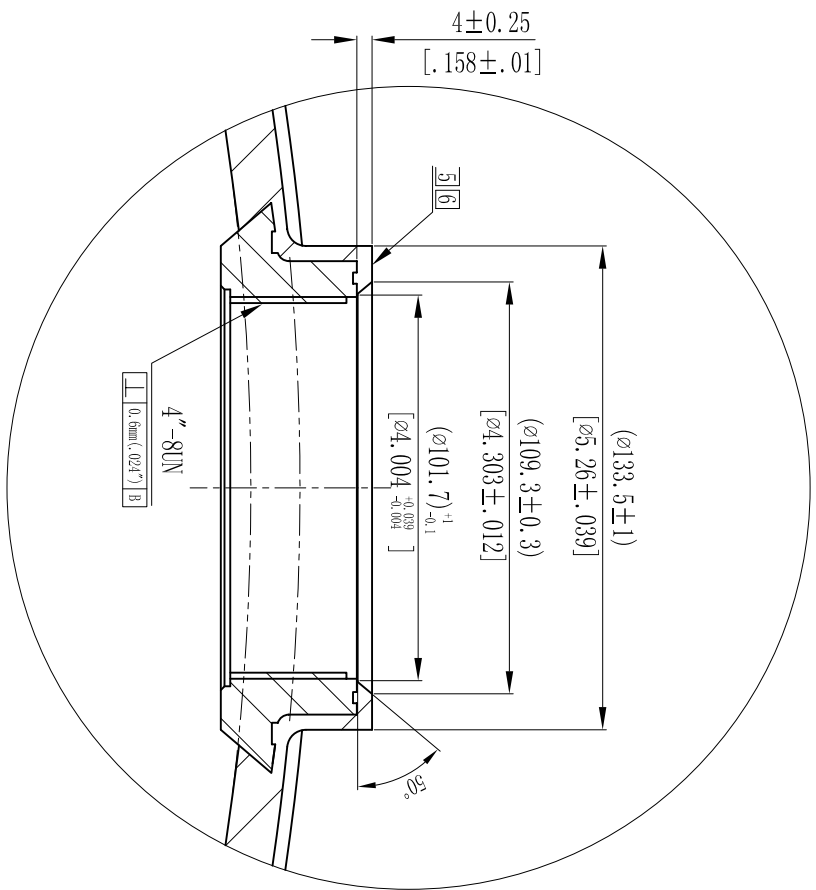
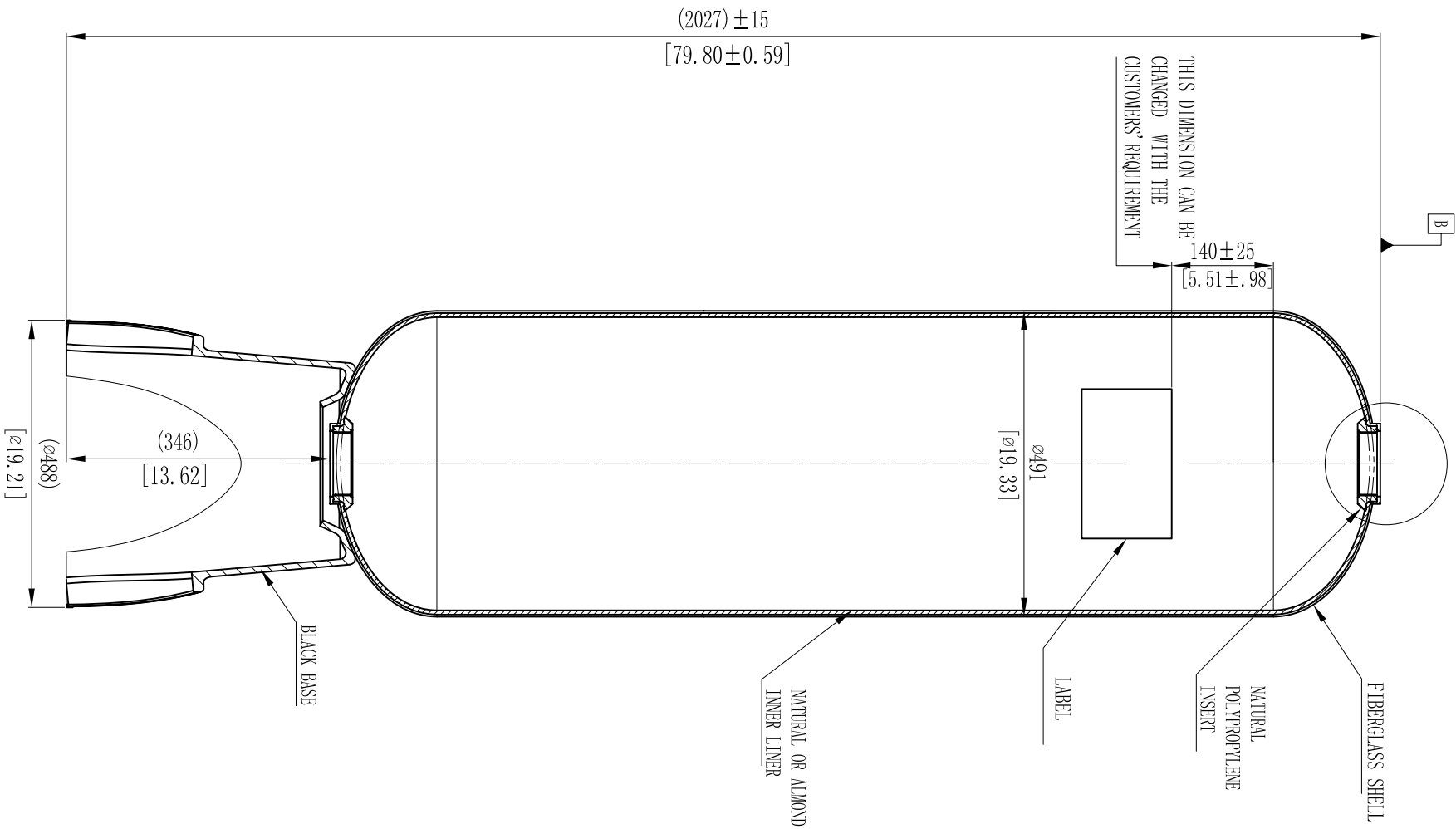

- NOTES:
- TANK MUST MEET ALL APPLICABLE SPECIFICATIONS OF NSF/ANSI 044 STANDARD, LATEST REVISION.
 - OPERATING SPECIFICATIONS:
 - MAXIMUM WORKING PRESSURE - 150 PSI (10.5BAR)
 - TEMPERATURE RANGE - 34-120° F (1-49°C)
 - MAXIMUM VACUUM - 5"Hg (127mm Hg)
 - VISUAL LINER INSPECTION
 - NO MORE THAN 10 INTERNAL OR EXTERNAL BLEMISHES OR BURNT DEBRIS.
 - NO INTERNAL OR EXTERNAL BLEMISHES OR BURNT DEBRIS LARGER THAN 3x3mm.
 - NO INTERNAL BLEMISHES OR BURNT DEBRIS ALLOWED.
 - ALL GLASS STRANDS FROM FIBERGLASS LINER TO BE BONDED AND COVERED.
 - SURFACE TO BE FREE OF NICKS, SCRATCHES, RESIN AND GLASS.
 - SURFACE FINISH.
 - DIMENSIONS IN PARENTHESIS ARE REFERENCE ONLY.
 - DIMENSIONS IN SQUARE PARENTHESIS ARE INCH UNIT.