

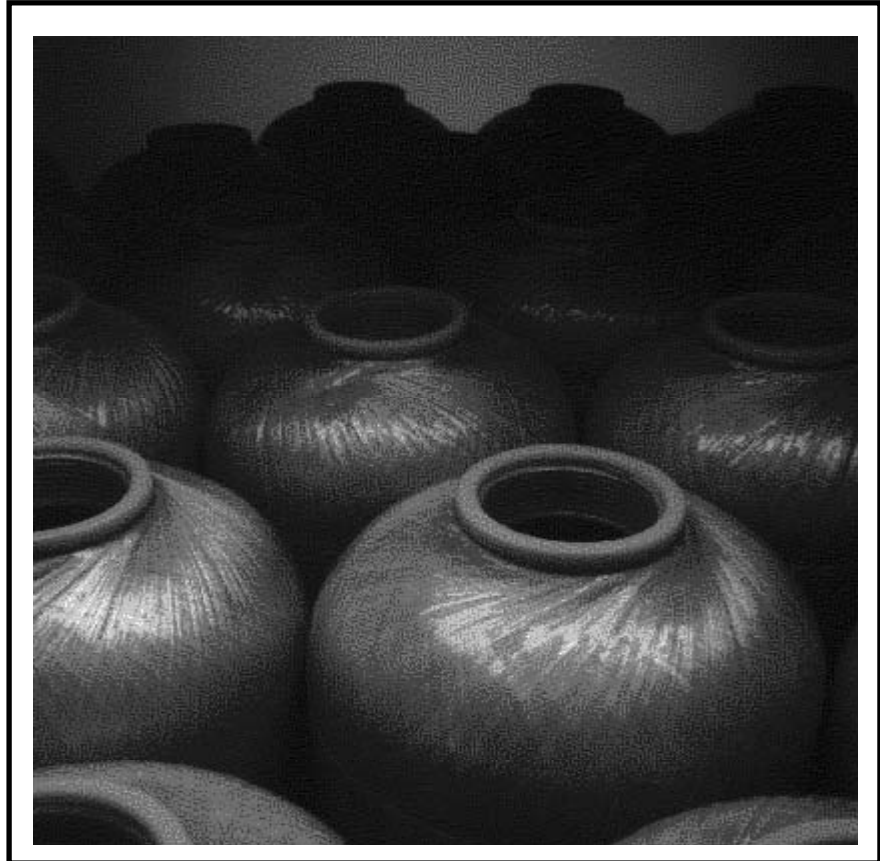

PARK Composite Pressure Tanks



Product Overview and Technical Information

Distributed by::

INAQUA
Vertriebsgesellschaft mbH

Langmaar 7
D - 41238 Mönchengladbach

Tel.: ++49 (0) 2166 - 850 840

CONTENT

Range of application

Nomenclature

Product Description

Residential, Portable Exchange and Light Industrial Tanks
Industrial Tanks

Technical Data

Dimensions and Volumes
Chemical Resistance
Pressure Stability
Temperature Stability
Colour Design
Base Design

Handling and Transport

Transport / Packaging
Installation recommendations

Warranty Conditions and Spare Delivery

Special Tank Designs

Fill - in Opening
Side Ports
Rubber bands and Rubber bases

APPLICATION RANGE

PARK pressure vessels are composite tanks. A blow molded seamless liner of non - permeable thermoplastic is overwounded with miles of epoxy reinforced fibreglass laminate for top strength and performance.

A wide application range is covered. The tanks are used when water will be filtered softened or demineralized. The processes where the tanks are used for reaching from active carbon filtration - iron removal - multimedia filtration - softening - demineralisation - portable exchange - special ion exchange processes.

The used materials and the production process allow an almost unlimited corrosion resistance for the applications in the water treatment as well as for a many diluted chemicals.

However beside the corrosion resistance the technical limits given in the following have to be considered.

Nomenclature

Following a guide explaining the tank nomenclature with the respective abbreviations:

RT - 735 Pressure Tank with **7"** (= 178 mm) inside diameter and a tank height without base of **35"** (= 889 mm) and a top - opening with a thread of 2,5" - 8 UN. The inliner-material of tank is ABS.
(ABS = Acryl Butadien Styrol) (1" = 25,4 mm)

RT - 1665 -45 Pressure Tank with **16"** (= 406 mm) inside diameter and a tank height without base of **65"** (= 1651 mm) and a top - opening with a thread of 4,5" - 8 UN. The inliner-material of tank is ABS

RT - 3072 - 6 - 6 V Pressure Tank with **30"** (= 762 mm) inside diameter and a tank height without base of **72"** (= 1814 mm) and a top and bottom - opening each with a thread of 6" - 8 UN. The inliner-material of tank is vinylester

RT - 4872 - F - F V Pressure Tank with **48"** (= 1219 mm) inside diameter and a tank height without base of **72"** (= 1834 mm) and a top - opening with a Flange of 6" inside diameter. The inliner-material of tank is vinylester

PRODUCT DESCRIPTION

RESIDENTIAL, PORTABLE EXCHANGE and LIGHT INDUSTRIAL TANKS

Diameter 5" through 22"
Tankvolume 5,1 litres up to 306 litres

one piece seamless TANK LINER

- blow molded from engineering grade thermoplastic
- smooth, fiber-free inner surface with wide chemical resistance
- liner materials with in compliance FDA under 21CFR -part 177
- not affecting by regenerating chemicals (acid/caustic) or DI - water

TESTING

- testing of PARK pressure tanks is performed to all standards, assuring top field performance

INDUSTRY APPROVED

- approved by NSL, UL and meets the requirement of WQA Standard S - 100
- rated for 10 bars operating pressure at 50 °C

STANDARD BASES

- for tanks 5" through 14" diameter
ABS - injected molded
- for tanks 16" diameter
rubber - compression molded
- for tanks 20" and 22" diameter
fiberglass - compression molded

OPTIONAL BASES

- for tanks 8" - 9" - 10" - 12" - 13" + 14"
rubber - compression molded
- for tanks 10" - 12" - 14" - 16" - 20" - 22"
with top and bottom opening
fiberglass, extended bases

precision injection molded THREADS

- for all standard industry valves and fittings

though OUTER LAMINATE

- continuous strands of fiberglass with high strength epoxy resin
- completely rust and corrosion free
- excellent impact and abrasion resistance

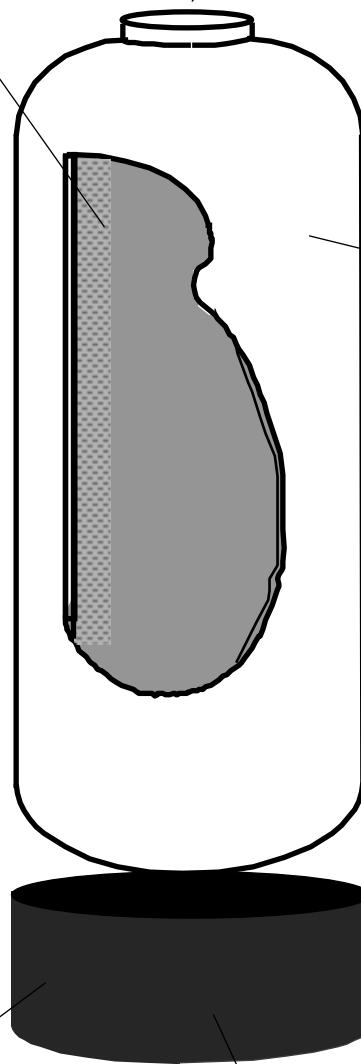

INDUSTRIAL LARGE CAPACITY TANKS

for commercial and industrial applications

Diameter	24 " through 48 "
Tank volume	390 litres up to 1756 litres

Features:

- **PARK** exclusive vinylester interior - fibre-free and good for all standard water treatment applications, including demineralisation.
- **PARK** filament wound epoxy / fibreglass outer laminate for top strength and performance
- Precision molded threads or exclusive fibreglass flange for standard valves and fittings
- Rated for 10 bars operating pressure at temperature of 50°C
- All industry approvals NSF, UL, WQA S -100

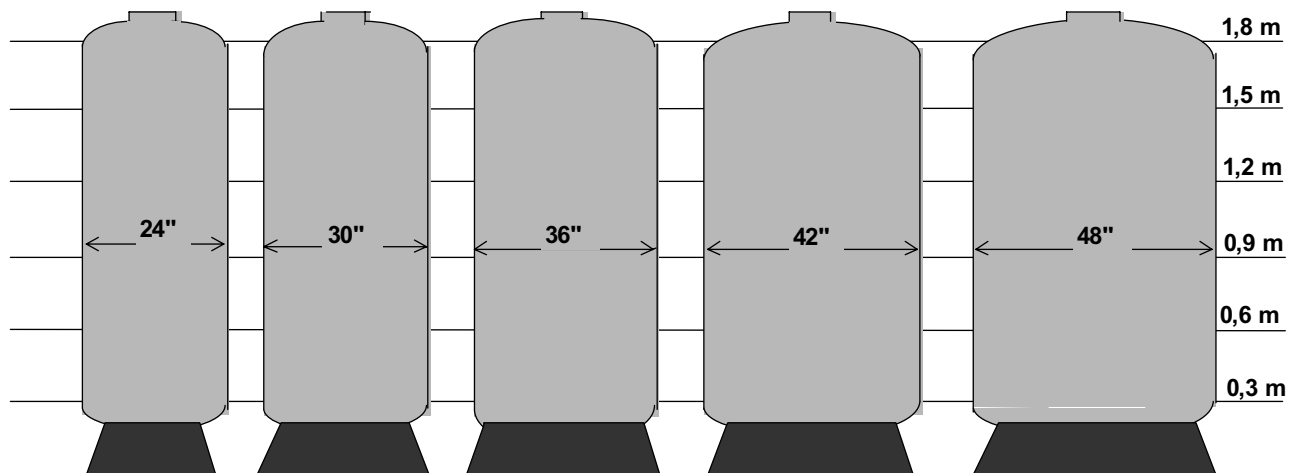

- **PARK** tank connections available for tanks with top openings and top and bottom openings threads
4" - 8 UN
4 1/2" - 8 UN
6" - 8 UN
6" flange

Flange models with top and bottom openings has an increased height

- **PARK** offers precision distributor systems - injection molded in engineering grade plastic for easy reliable assembly and top field performance

TECHNICAL DATA Dimensions and Tankvolumes

Tank-type	"A" Diameter in mm	"B" Heigth without Base in mm	"C" Heigth with Base in mm	Volume total in Litres	Volume Dome in Litres	Tank- area in m ²
RT-523	132	602	620	6,3	0,57	0,012
RT-612	165	318	328	5,1	0,68	0,020
RT-618	165	465	475	7,7		
RT-629	165	724	742	13,1		
RT-635	165	889	899	17,0		
RT-724	193	607	617	14,42	1,00	0,028
RT-730	193	762	770	18,4		
RT-735	193	889	902	22,63		
RT-740	193	1016	1024	25,47		
RT-744	193	1118	1125	27,18		
RT-817	213	427	434	11,8	1,22	0,034
RT-818	213	472	480	13,3		
RT-824	213	607	612	18,1		
RT-830	213	757	762	22,9		
RT-835	213	894	899	27,7		
RT-840	213	986	1016	31,2		
RT-844	213	1107	1113	35,4		
RT-917	234	429	442	13,8	1,68	0,041
RT-935	234	892	904	33,42		
RT-940	234	1016	1029	37,36		
RT-942	234	1069	1074	39,93		
RT-948	234	1219	1232	43,87		
RT-1022	259	558	566	22,0	2,22	0,051
RT-1035	259	889	902	39,6		
RT-1040	259	1016	1029	45,3		
RT-1044	259	1120	1143	46,0		
RT-1047	259	1194	1207	53,8		
RT-1054	259	1369	1382	62,3		
RT-1060	259	1511	1524	67,7		
RT-1236	325	899	909	62	5,08	0,080
RT-1242	325	1074	1085	73,88		
RT-1248	325	1219	1227	84,7		
RT-1252	325	1323	1334	93,98		
RT-1354	333	1372	1392	101,9	5,81	0,084
RT-1447	356	1163	1179	101,93	6,80	0,096
RT-1465	356	1626	1633	142,39		
RT-1636	409	917	932	99,2	10,02	0,127
RT-1653	409	1362	1377	154,4		
RT-1665	409	1631	1643	186,6		
RT-1865	476	1665	1664	258,7	28,33	0,133
RT-2244	554	1029	1204	218,28	26,71	0,236
RT-2254	554	1346	1458	274,03		
RT-2260	554	1499	1610	306,59		
RT-2460	625	1534	1656	390,6	46,26	0,299
RT-2471	625	1814	1943	448,5		
RT-3062	785	1560	1793	596	78,92	0,474
RT-3072	785	1814	2047	724,1		
RT-3672	942	1829	2062	1063,6	131,53	0,685
RT-4262	1054	1580	1930	1096	167,81	0,856
RT-4272	1054	1834	2184	1317,2	167,81	0,856
RT-4872	1219	1834	2184	1756,2	242,65	1,151

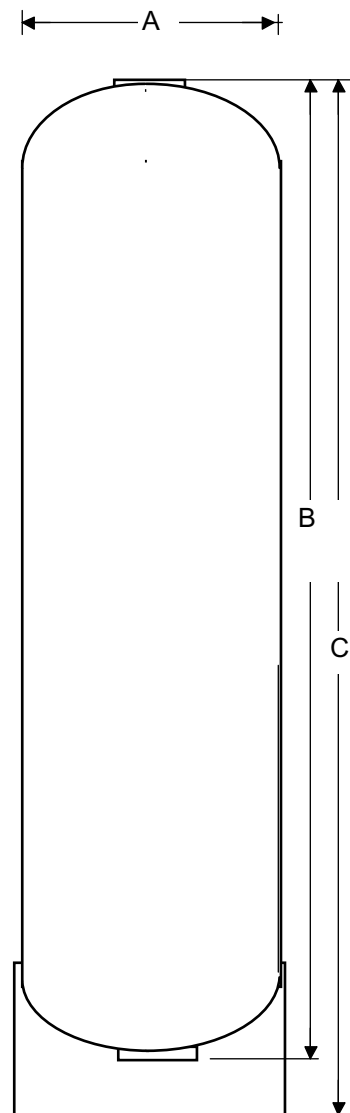

Chemical Resistance

The PARK pressure vessels design includes an inliner that is reinforced by an exterior epoxy / glass roving matrix. The liners used provide a reliable barrier to chemical corrosion and will have slightly different properties based on the ratings below. All liner material meet FDA standards for potable water. Use these ratings as a guide only. Actual performance will depend on concentrations, temperature and solution chemistry. If no rating is shown, data are not available.

Comparative ratings:

1	excellent
2	very good
3	fair
4	poor

Chemical Description	ABS	Vinylester	Chemical Description	ABS	Vinylester
Acetic acid - glacial	4	4	Hydrochloric Acid 25%	1	1
Acetic acid - 50%	1	1	Hydrofluoric Acid 20%	2	1
Acetone	4	4	Hydrogen Peroxide	2	1
Aluminum Chloride	1	1	Lime Chloride	2	-
Ammonia 20C	2	2	Magnesium Salts	2	1
Ammonium Hydorxide 30%	2	1	Methyl Chloride	4	4
Arsenic 20FC	-	1	Nitric Acid 25%	3	1
Benzene 20C	4	4	Ozone (50 ppm)	2	-
Bleach 12% Cl2	4	2	Petroleum Jelly	4	-
Bromine Water	4	2	Photographic Solutions	2	-
Butyric acid	4	1	Plating Solutions	2	-
Calcium Carbonate	1	1	Potassium Carbonate	1	1
Carbonic Acid	1	1			
Chlorine-water	2	1			
Chlorine-wet	4	-			
Chromic Acid 20%	3	4			
Copper Sulphate	1	1			
DOW 200 silicone	1	1			
Ethylene chloride	4	4			
Ferric Chloride	1	1			
Fluorine	4	-			
Iodine (crystals)	4	-			
Isopropyl alcohol 50%	3	1			

Pressure Stability

All **PARK** pressure tanks are designed and approved for an operating pressure up to 10 bars at a maximum water temperature of 50°C.

The pressure vessels should not be used for hydro-pneumatic applications or vacuum operation. The use of the tanks as storage tank is not recommended for this application local legal regulations have to be followed.

The **PARK** pressure vessels have a height extension of 2 mm per meter tank height at maximum operating pressure. Flexible connections or height-balancing pipe installation in case of pressure variations or at „ high pressure operation “ might be considered for installation.

Beside the height extension also an width extension of about 10 mm per meter tank diameter can occur. This elastic performance is normal and does not limit the application.

Temperature Stability

All **PARK** pressure vessels can be operated at temperatures up to 50°C.

Higher operating temperatures for the small residential and light commercial tanks (RT 5xx up to RT 12xx) are possible. Temperature limits given on request.

Colour Design

PARK pressure vessels are produced in natural colour, opal white-green as per the epoxy-glasfibre-material. The bases are black.

Special colours like grey, white, blue, green can be supplied on request and depends on the number of ordered tanks.

Base Design

Depending on the tanksize and application the bases are different designed. For small cabinet - softening systems tanks can also be delivered without bases.

For the residential and light commercial tanks following bases are standard bases:

- for tanks 5“ through 14“ diameter	ABS - injected molded
- for tanks 16“ diameter	rubber - compression molded
- for tanks 20“ and 22“ diameter	fibreglass - compression molded

Optional following bases could be supplied:

- | | |
|---|---|
| - for tanks 8" - 9" - 10" - 12" - 13" + 14" | rubber - compression molded |
| - for tanks 10" - 12" - 14" - 16" - 20" - 22" | with top and bottom opening
fibreglass, extended bases |

The large capacity tanks RT 24xx up to RT 48xx are designed with extended bases made from fibreglass with an assembling side hole to fit the connection to the piping and filter distribution system.

HANDLING and TRANSPORT

Transport / Packaging

PARK pressure vessels are carefully checked and packed. Tanks from sizes RT 12xx and larger are packed and sent in single boxes. Smaller tanks are depending on the number of tanks in single or multiple boxes packed.

Damages caused by transport should be handled direct with the respective handling forwarder.

For local installation and local transport use if needed transport lifting gears which are wounded around the tank. Do not use the flanges or the thread openings or other tank openings to lift or transport the tanks.

The tanks should not be rolled or vertically pulled over the ground.

Installation Recommendations

Residential and light commercial tanks can be installed without ground fixing. For tanks from tanks sizes RT 30xx and larger we recommend (but not necessarily) to fix the tanks on the installation ground.

Always tanks should be installed on horizontal level.

Valve batteries and piping-systems are to be supported by pipe-frames or other supporting devices.

The connecting piping should be executed tensionfree.

The **PARK** pressure vessels have a height extension of 2 mm per meter tankheight at maximum operating pressure. Flexible connections or height-balancing pipelaying in case of pressure variations or at „ high pressure operation “ might be considered for installation.

If adapters and filter nozzle systems are used which are not supplied by PARK / INAQUA the thread sizes and the sealing procedures have to be carefully checked. Contact PARK / INAQUA for any doubt.

For sealing or fitting of adapters and filter nozzle systems into the tank openings use only high quality lubricants based on silica based products (for example DOW Corning's SILICON 111 compound or equivalent). **Do not use ordinary plumber / fitter lubricants** like petroleum jelly or sprays. These kinds of lubricants could destroy the plastic of the adapters.

In case of a glue connection between the adapters and a PVC – piping system only use PVC - cement for the connection. **Do not use PVC - „Tangit“** or equivalent products which do not have a reliable long term performance.

Do not drill in openings for additional adapters or threads. This will lead to irreversible leakages.

The pressure vessels should not be used for hydropneumatic applications or vacuum operation. The use of the tanks as storage tank is not recommended for this application local legal regulations have to be followed.

In case that vacuum or water hammer can occur provisions have to be considered to avoid this conditions.

WARRANTY CONDITIONS and SPARE DELIVERY

Warranty Conditions

Each pressure vessel manufactured by PARK International is covered by a limited warranty. For water conditioning, de-ionization and approved chemical applications PARK tanks are warranted to be free of defects for 3 years from date of shipment.

All pressure vessels must be used in operating conditions that conform to performance limitations as shown on each tank label and described in the technical brochures.

Warranty coverage does not extend to external impact fractures, vacuum conditions or fractures due to water hammer

The warranty is invalid if improper O - ring or thread lubricant is used in assembly or retrofit.

In case of removing or destroying of the PARK International tank-label and / or the serialnumber the warranty will be nil and voided.

The warranty covers only the spare delivery of the relevant tanks to customers initial shipping address. Additional coverage of other costs are expressly excluded.

The acceptance of a warranty is without a case description and return authorisation of the distributor not possible.

Spare Delivery

If a warranty case is accepted the PARK International tank-label has to be sawed out or otherwise to be removed without destroying the label and to be send to the distributor.

The label and the serialnumber have to be readable.

SPECIAL TANK DESIGNS

Fill - in Opening

1" Fill - In / Sensor Opening Art. No. 420 910

- for tanksizes RT 7xx up to RT 22xx
- 1" - opening with full thread
- material: ABS
- with plug and O - ring
- enough place for valve installation and valve maintenance
- operating pressure max. 10 bars

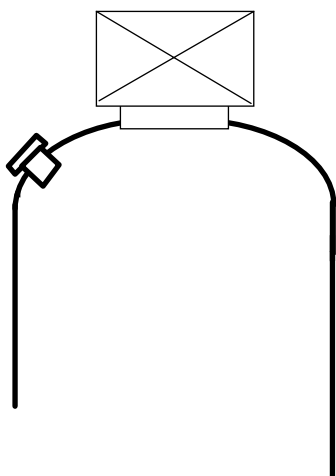
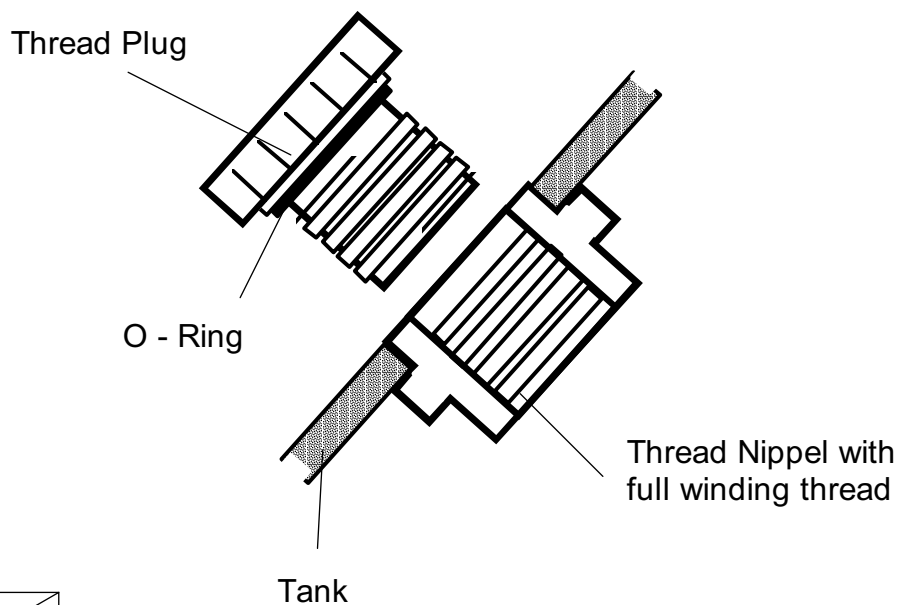

1" Fill - In / Sensor Opening Art. No. 420 920
- for tanksizes RT 24xx up to RT 48xx with NPT Thread

1 1/2" Fill - In / Sensor Opening Art. No. 420 930
- for tanksizes RT 24xx up to RT 48xx with NPT Thread

SPECIAL TANK DESIGNS

Side Ports

- side ports are available in 2" and 3" NPT threads
- for tank sizes RT 24xx up to RT 48xx
- lengths L1, L2 and or L3 given in table below
- design with different 2" and 3" NPT thread
- Type A with internal and external thread

Type	Volume In Liter.	In / Out*	L1	L2 in mm	L3	L _{ges}
RTV 2471-2S-2S	448	DN 20 / DN 50	350	1146	650	2146
RTV 3072-2S-2S	724	DN 50 / DN 50	410	1026	700	2136
RTV 3672-2S-2S	1.063	DN 50 / DN 50	460	940	750	2150
RTV 4272-3S-3S	1.317	DN 80 / DN 80	510	844	830	2184
RTV 4872-3S-3S	1.756	DN 80 / DN 80	570	734	880	2184

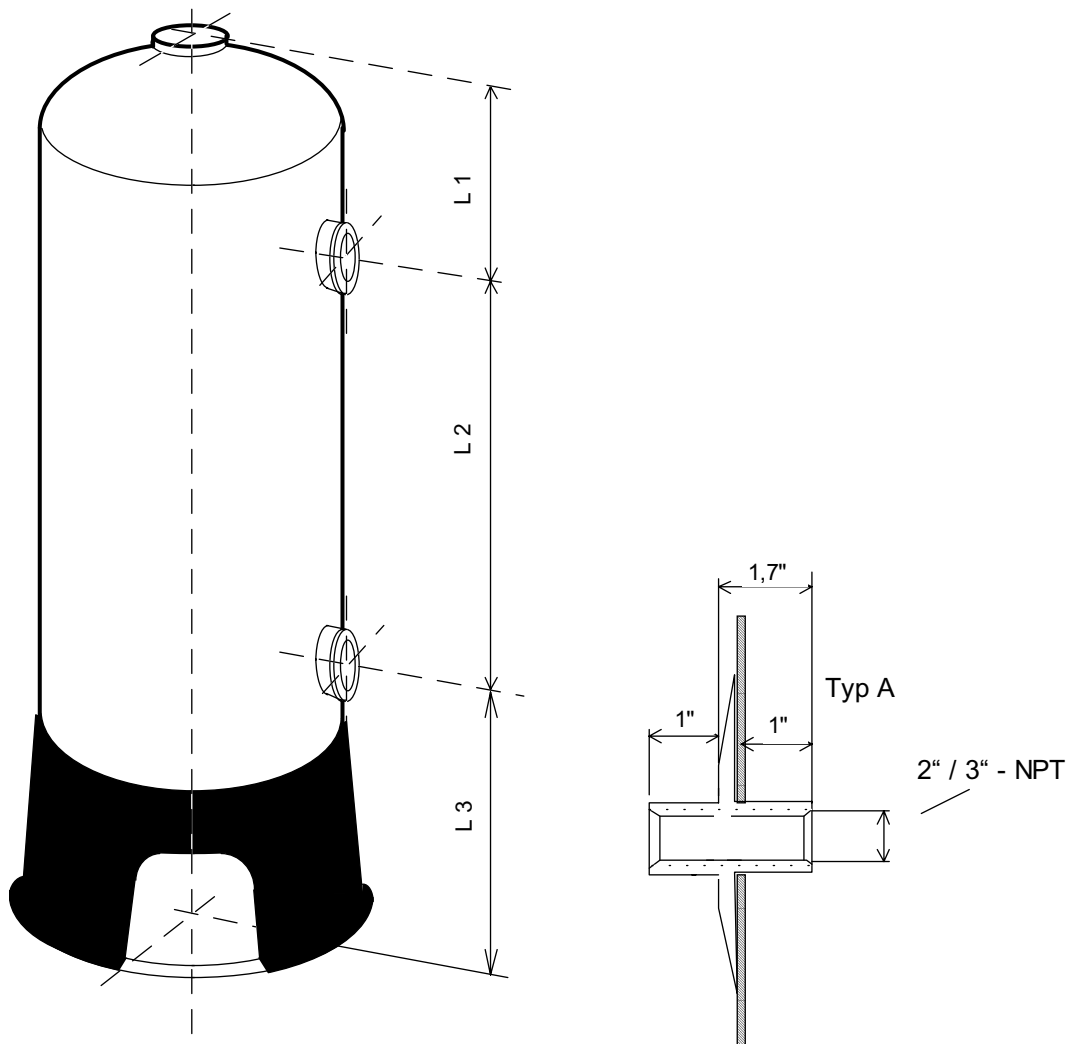

SPECIAL TANK DESIGNS

Rubber bands and Rubber bases

- in case of portable exchange tanks for external regeneration and mobile application
- to avoid shock and transport damages

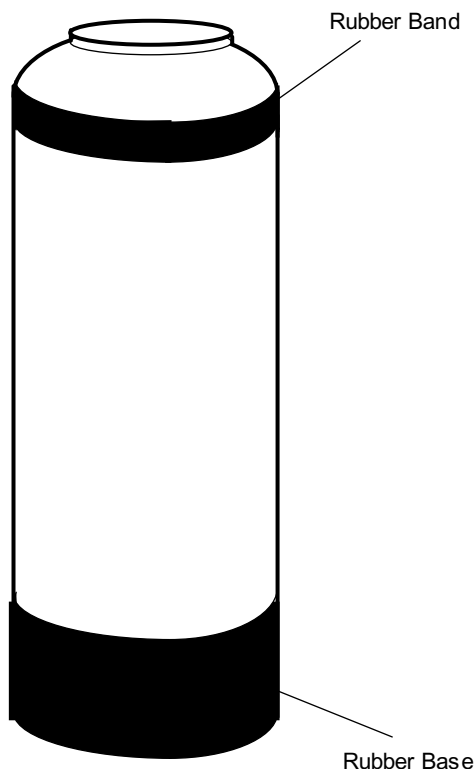

Bumper Bands and Rubber Bases

Art. No.	Description			Material
420 850	Bumper Band 6"	for RT-6xx - Tank	SB 6	Hardrubber
420 851	Bumper Band 7"	for RT-7xx - Tank	SB 7	Hardrubber
420 852	Bumper Band 8"	for RT-8xx - Tank	SB 8	Hardrubber
420 853	Bumper Band 9"	for RT-9xx - Tank	SB 9	Hardrubber
420 854	Bumper Band 10"	for RT-10xx - Tank	SB 10	Hardrubber
420 855	Bumper Band 12"	for RT-12xx - Tank	SB 12	Hardrubber
420 856	Bumper Band 13"	for RT-13xx - Tank	SB 13	Hardrubber
420 857	Bumper Band 14"	for RT-14xx - Tank	SB 14	Hardrubber
420 862	Base 8"	for RT-8xx - Tank	GF 8	Hardrubber
420 863	Base 9"	for RT-9xx - Tank	GF 9	Hardrubber
420 864	Base 10"	for RT-10xx - Tank	GF 10	Hardrubber
420 865	Base 12"	for RT-12xx - Tank	GF 12	Hardrubber
420 866	Base 13"	for RT-14xx - Tank	GF13	Hardrubber
420 867	Base 14"	for RT-14xx - Tank	GF 14	Hardrubber