

3" - FILTERDÜSEN SYSTEM DSAU - F UNTEN

3" - FILTERNOZZLE SYSTEM DSAU - F BOTTOM

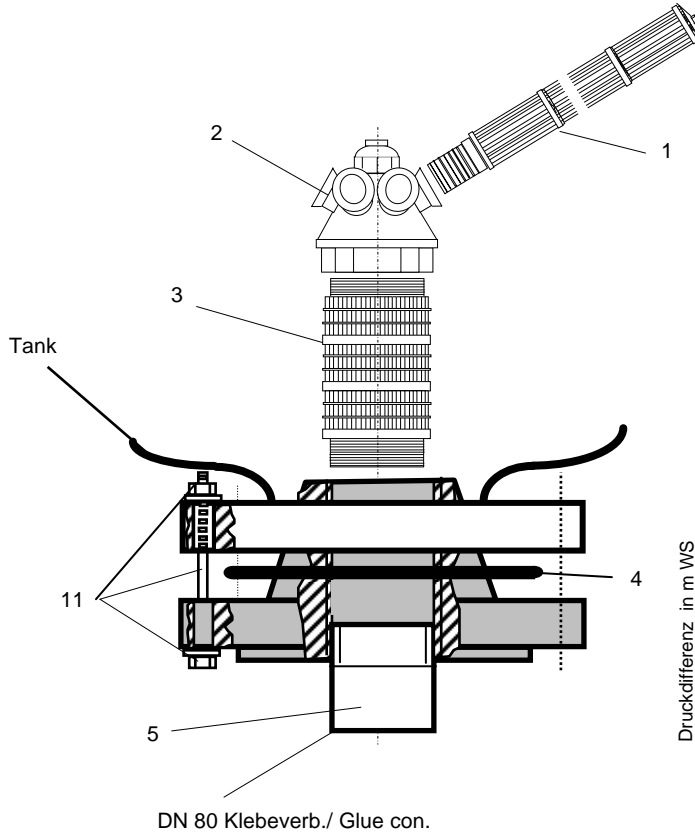

<p>Top + Bottom 6" - Flange</p>	<p>max. 50°C min. 5°C</p>
<p>handfest handtight 5 NM DSAU 42</p>	<p>max. 10 bar / 150 psi</p>
	<p>0,2 mm — 0,5 mm</p>

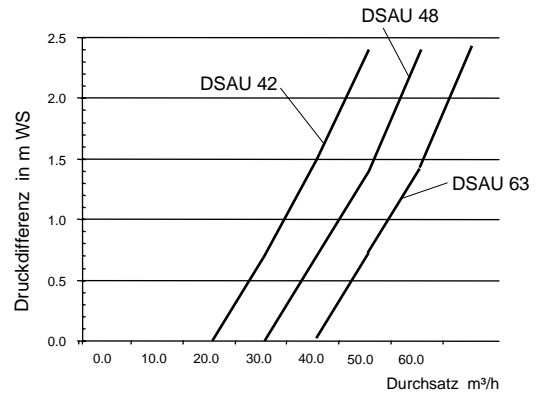

Art. No.	Bezeichnung / Description	Pos. /Iter	Material	Type	Bemerk. / Remark
420 21x	Filterdüse / Filternozzle 8 Stück / pcs	1	PP	FD xx	vom Tankdurchm. abhängig / depending on Tankdiameter
420 220	Düsenmittelstück / Hub	2	PP	HU 30 - 8	
420 230	Verlängerung / Extension	3	PVC	AV - 3 0.2	zur Verbindung von HB30-8 an Flansch FLA 6030 - SW 0.2mm
420 735	O-Ring / O-Ring	4	EPDM	OR 60	
420 300	Flanschadapter / Flangeadapter	5	PVC	FLA 6030	6" Flansch mit 3" Gewinde
420 190	Schraube / Bolt	11	SS	FL-SM	M8 12 Stück / Pieces
421 190	U-Scheibe & Federr./Washer & Spring	11	SS	FL-SM	M8 12 Stück / Pieces
422 190	Mutter / Nut	11	SS	FL-SM	M8 12 Stück / Pieces

3" Düsenysteme mit Flansch unten				Einbauart A	
3" Filternozzlesystem with Flange bottom				Installationtype A	
420 460	DSAU 42 / 6030-F3" - 0.2 A	kompl./ compl.	für / for 42 x XX		
420 465	DSAU 48 / 6030-F3" - 0.2 A	kompl./ compl.	für / for 48 x XX		
420 468	DSAU 63 / 6030-F3" - 0.2 A	kompl./ compl.	für / for 63 x XX		